



# AE series

## M8 cylindrical inductive sensors



M8 cylindrical

### features

- Extremely reduced measure
- Metal housing
- LED status indicator 360° visible
- IP 67 housing protection
- ATEX models, cat. 3, available on request
- Complete protection against electrical damages
- Standard and long distance models
- Standard and short body housing



### web contents



- Application notes
- Photos
- Catalogue / Manuals



### code description

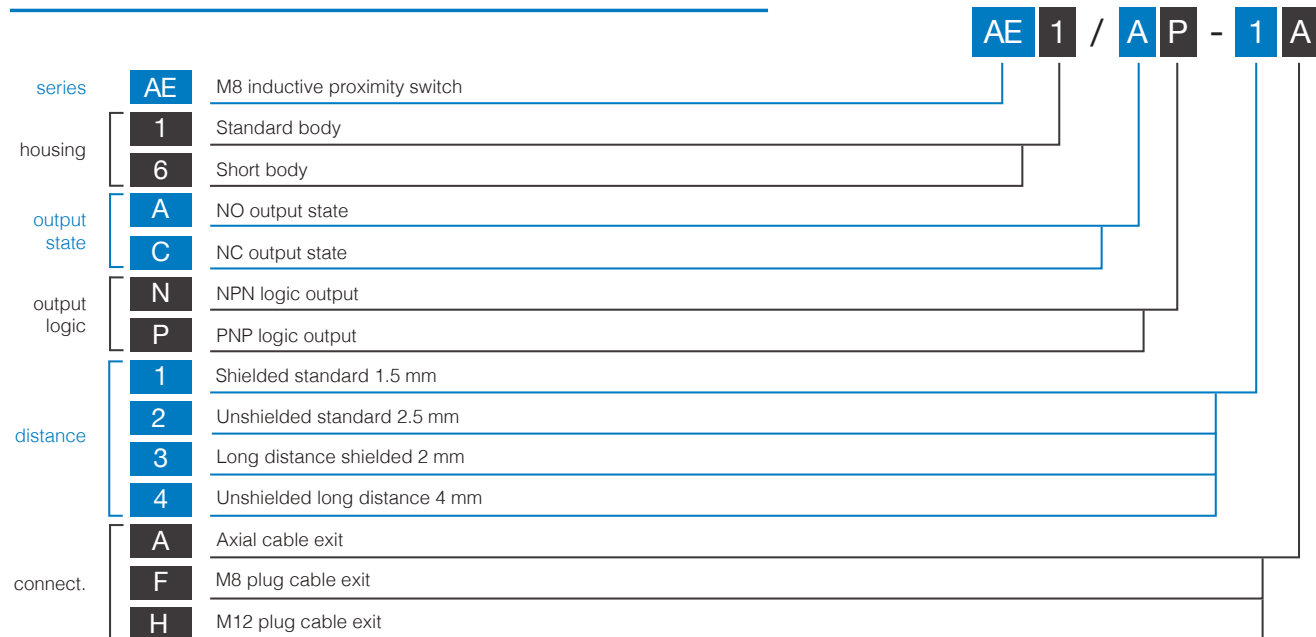

(\*) ATEX models available, contact our Sales Dept. for further information.

M8 cylindrical

## available models

### standard housing

diameter	installation	distance	plug	distance (mm)	NPN/NO	NPN/NC	PNP/NO	PNP/NC		
M8	shielded	standard	cable	1.5	AE1/AN-1A	AE1/CN-1A	AE1/AP-1A	AE1/CP-1A		
			M8		AE1/AN-1F	AE1/CN-1F	AE1/AP-1F	AE1/CP-1F		
			M12		AE1/AN-1H	AE1/CN-1H	AE1/AP-1H	AE1/CP-1H		
			unshielded	cable	2.5	AE1/AN-2A	AE1/CN-2A	AE1/AP-2A	AE1/CP-2A	
				M8		AE1/AN-2F	AE1/CN-2F	AE1/AP-2F	AE1/CP-2F	
				M12		AE1/AN-2H	AE1/CN-2H	AE1/AP-2H	AE1/CP-2H	
	shielded	long distance	cable	2	AE1/AN-3A	AE1/CN-3A	AE1/AP-3A	AE1/CP-3A		
					M8	AE1/AN-3F	AE1/CN-3F	AE1/AP-3F	AE1/CP-3F	
					M12	AE1/AN-3H	AE1/CN-3H	AE1/AP-3H	AE1/CP-3H	
			unshielded	cable	4	AE1/AN-4A	AE1/CN-4A	AE1/AP-4A	AE1/CP-4A	
						M8	AE1/AN-4F	AE1/CN-4F	AE1/AP-4F	AE1/CP-4F
						M12	AE1/AN-4H	AE1/CN-4H	AE1/AP-4H	AE1/CP-4H

## available models

### short housing

diameter	installation	distance	plug	distance (mm)	NPN/NO	NPN/NC	PNP/NO	PNP/NC		
M8	shielded	standard	cable	1.5	AE6/AN-1A	AE6/CN-1A	AE6/AP-1A	AE6/CP-1A		
			M8		AE6/AN-1F	AE6/CN-1F	AE6/AP-1F	AE6/CP-1F		
			M12		AE6/AN-1H	AE6/CN-1H	AE6/AP-1H	AE6/CP-1H		
			unshielded	cable	2.5	AE6/AN-2A	AE6/CN-2A	AE6/AP-2A	AE6/CP-2A	
						M8	AE6/AN-2F	AE6/CN-2F	AE6/AP-2F	AE6/CP-2F
						M12	AE6/AN-2H	AE6/CN-2H	AE6/AP-2H	AE6/CP-2H
	shielded	long distance	cable	2	AE6/AN-3A	AE6/CN-3A	AE6/AP-3A	AE6/CP-3A		
					M8	AE6/AN-3F	AE6/CN-3F	AE6/AP-3F	AE6/CP-3F	
					M12	AE6/AN-3H	AE6/CN-3H	AE6/AP-3H	AE6/CP-3H	
			unshielded	cable	4	AE6/AN-4A	AE6/CN-4A	AE6/AP-4A	AE6/CP-4A	
						M8	AE6/AN-4F	AE6/CN-4F	AE6/AP-4F	AE6/CP-4F
						M12	AE6/AN-4H	AE6/CN-4H	AE6/AP-4H	AE6/CP-4H





## correction factors

code	steel FE 360	copper	alluminium	brass	stainless steel
AE*/**-1*	1	0.29	0.38	0.49	0.78
AE*/**-2*		0.43	0.51	0.59	0.83
AE*/**-3*		0.35	0.43	0.52	0.78
AE*/**-4*		0.47	0.52	0.58	0.79

AE

382



	AE*/**-1*	AE*/**-2*	AE*/**-3*	AE*/**-4*
				
nominal sensing distance	1.5 mm	2.5 mm	2 mm	4 mm
operating distance	0...1.21 mm	0...2.02 mm	0...1.62 mm	0...3.24 mm
hysteresis	1...20% Sr			
standard target	8x8 mm FE360			12x12 mm FE360
repeatability	5%			
operating voltage	10...30 Vdc			
max ripple content	≤ 10%			
output type	NPN or PNP - NO or NC			
output current	≤ 200 mA			
output voltage drop	≤ 1,8 V @ 200 mA			
no-load supply current	10 mA			
leakage current	≤ 10 µA			
switching frequency	5 kHz			
power on delay	50 ms			
ambient temperature range	-25...+70 °C			
temperature drift of Sr	10%			
short-circuit protection	●			
voltage reversal protection	●			
induction protection	●			
shocks and vibrations	IEC 60947-5-2			
weight	20 g connector / 45 g cable			
LEDs	yellow LED output state			
protection degree	IP 67 ( EN60529 )			
EMC	in conformity with the EMC Directive, according to IEC 60947-5-2			
housing material	nickel-plated brass			
active head material	PBT			
connection	cable 2 m PVC / plug M8 or M12			
tightening torque	3 Nm			

# electrical diagrams of connections

3 wires versions

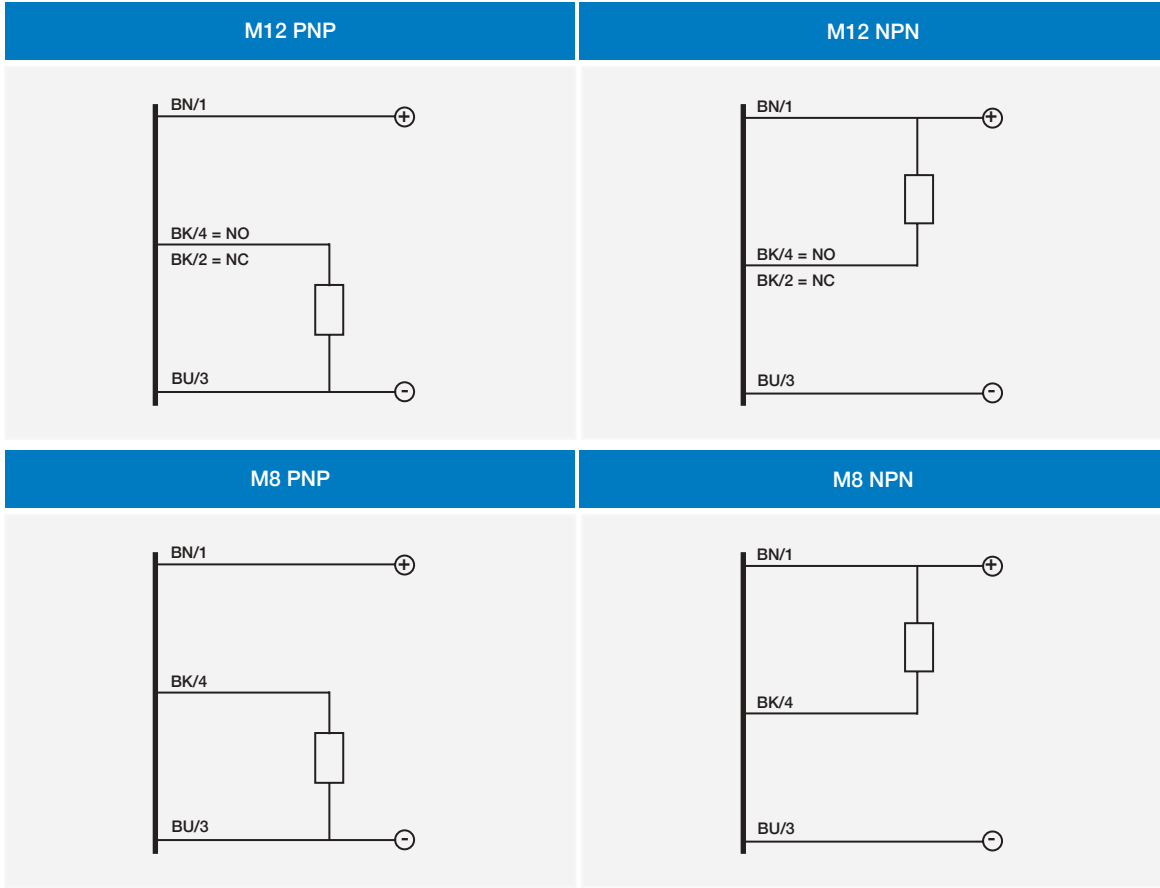

- BN** brown
- BU** blue
- BK** black
- WH** white

- BN** brown
- BU** blue
- BK** black
- WH** white

## plug

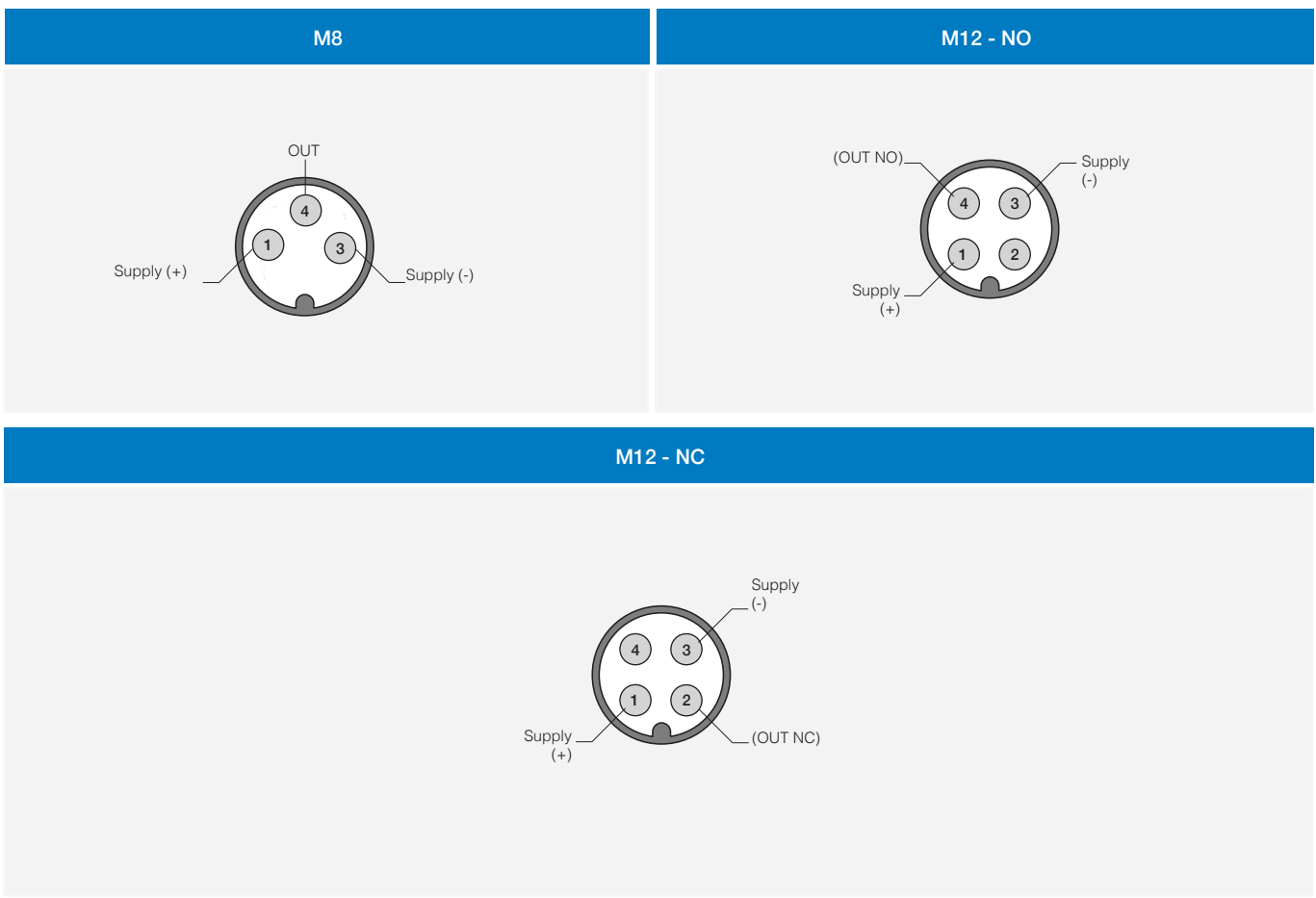

# response diagram



M8 cylindrical

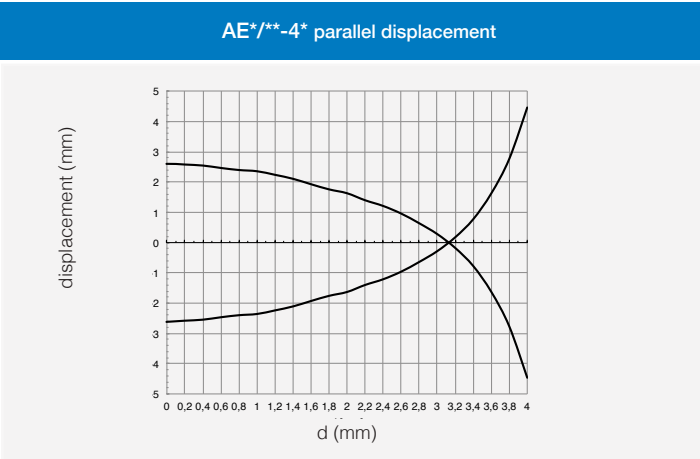
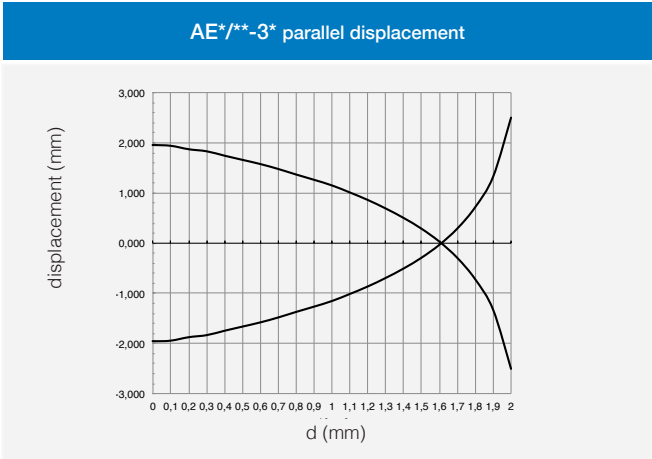
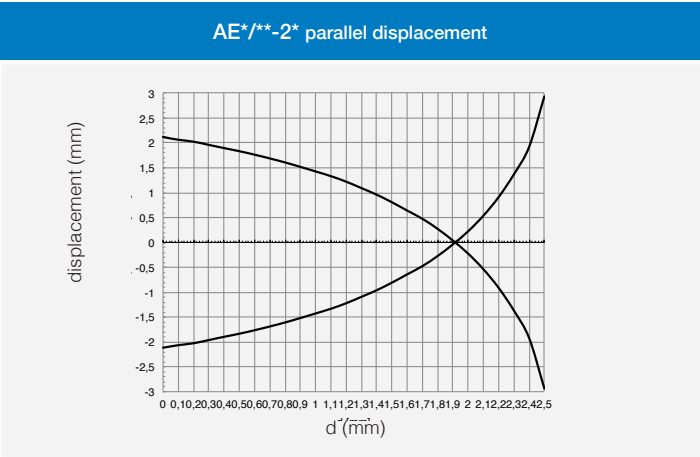
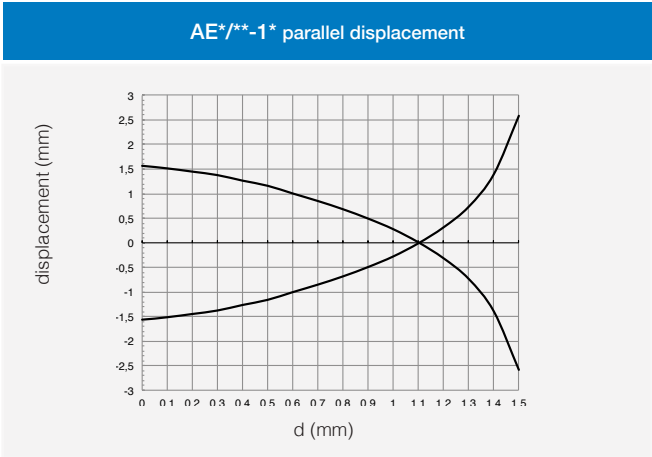

# installation

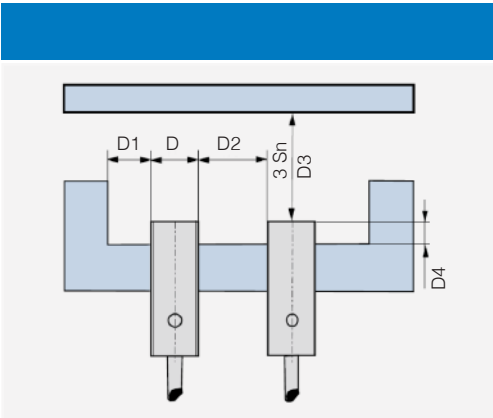

code	D4	D1	D2	D3
AE*/**-1*	≥ 1.6 mm	≥ 3.25 mm	≥ 6.5 mm	≥ 4.5 mm
AE*/**-2*	≥ 5 mm	≥ 6.5 mm	> 13 mm	≥ 7.5 mm
AE*/**-3*	≥ 1.6 mm	≥ 3.25 mm	≥ 6.5 mm	≥ 6 mm
AE*/**-4*	≥ 8 mm	≥ 6.5 mm	> 13 mm	≥ 12 mm



# dimensions (mm)

M8 cylindrical

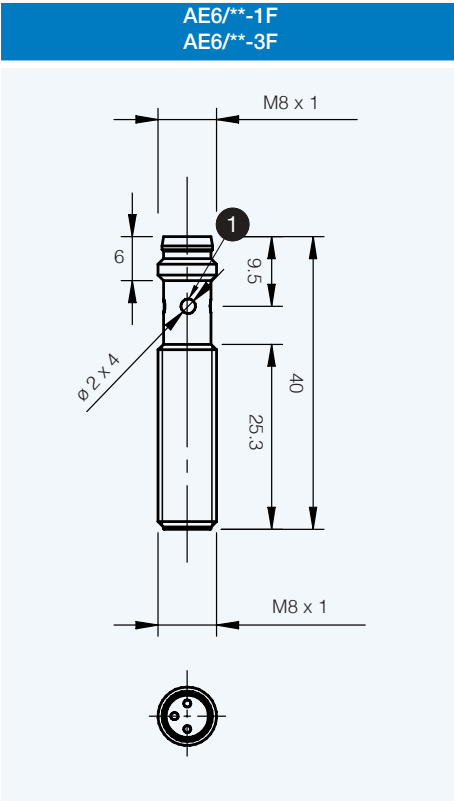
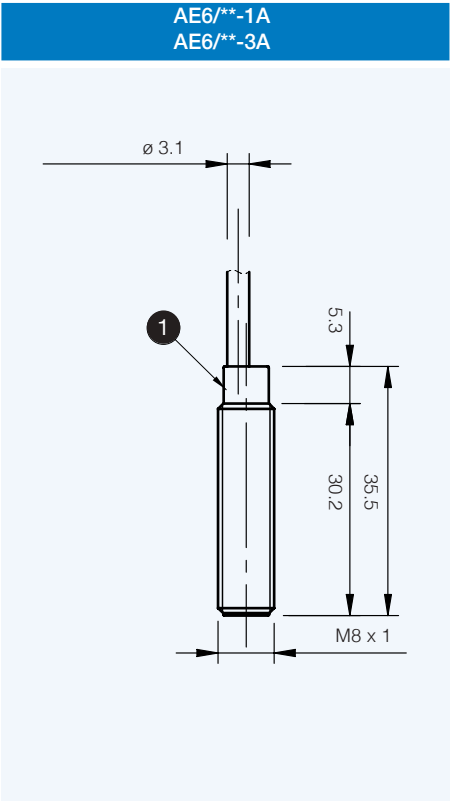
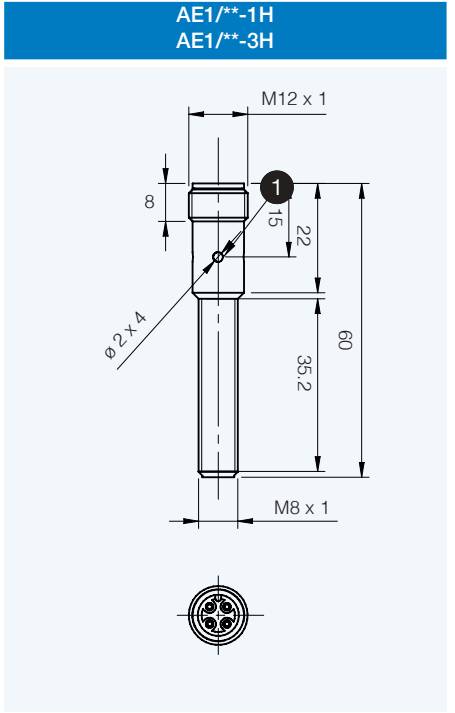
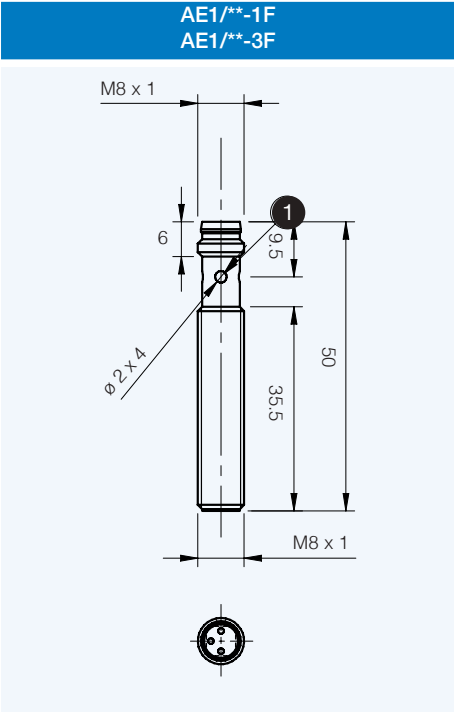
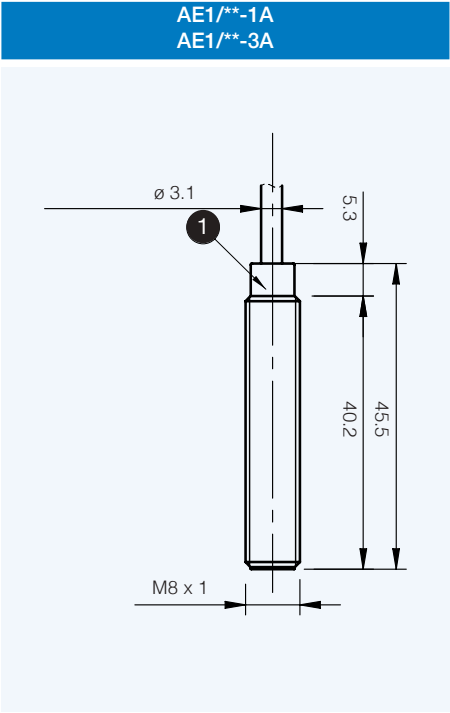

**1** LED



AE1/\*\*-2A  
AE1/\*\*-4A

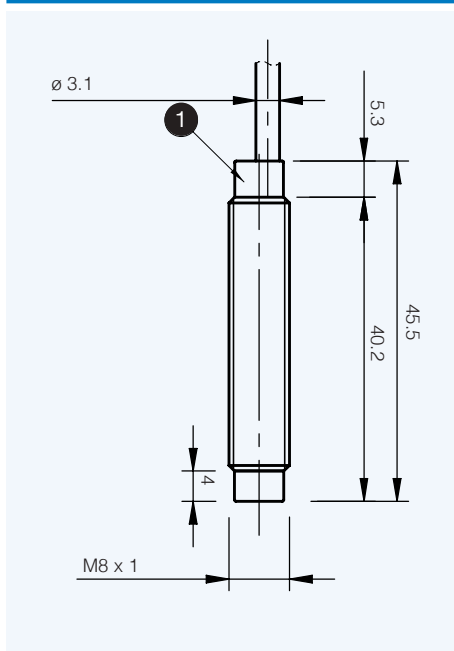

AE1/\*\*-2F  
AE1/\*\*-4F

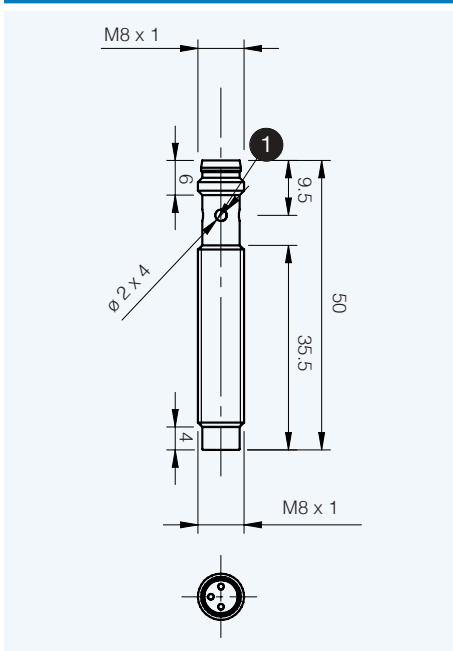

AE1/\*\*-2H  
AE1/\*\*-4H

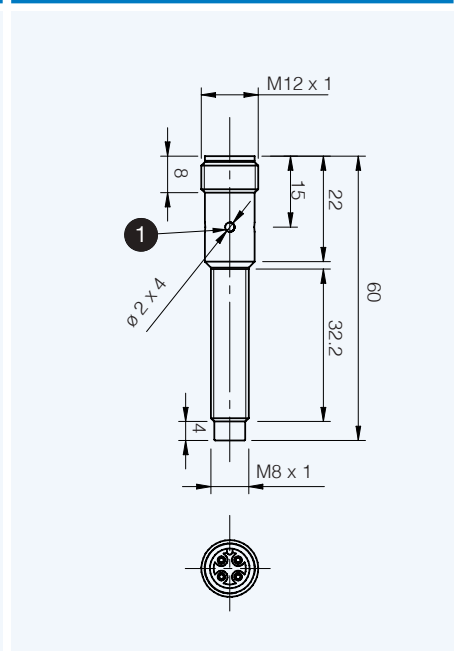

AE6/\*\*-2A  
AE6/\*\*-4A

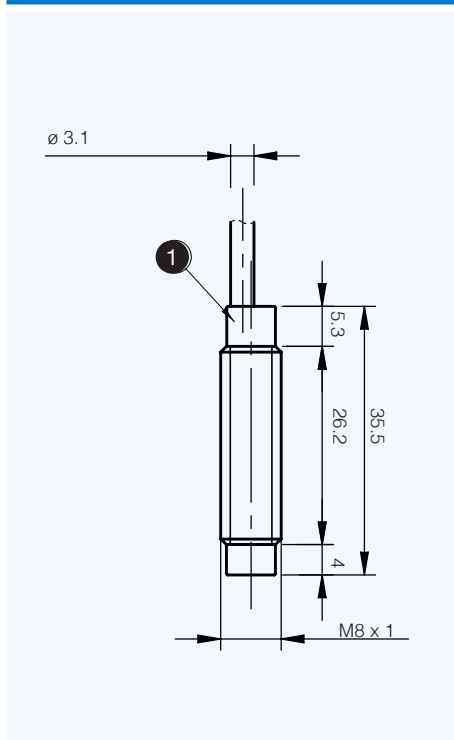

AE6/\*\*-2F  
AE6/\*\*-4F

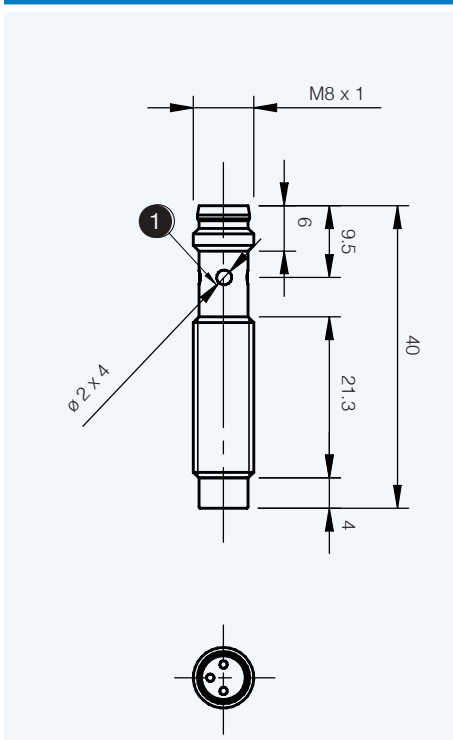

### dimensions (mm)

accessories included

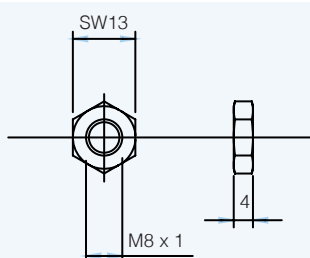

metallic  
nut (2 x)